



Cairo University
Faculty of Engineering
Credit Hours System



Electrical Energy Engineering Program EEE

May 2020

Electrical Engineers: What they do ?



- Develop, design or update specifications and designs for electrical systems and equipment
- Design methods to generate, distribute and manage electricity
- Design automated and computerised methods to control industrial processes
- Calculate the cost of projects, and materials needed
- Supervise the installation and maintenance of systems and equipment

Electrical Energy Engineering: A Growing Field for Opportunities



- Global transition into renewable and sustainable forms of energy.
- Worldwide trend for electrical applications for more energy saving and green economy.
- Constant growth of the local market for renewable energy and industrial automation.

FIGURE 1: RENEWABLE ENERGY EMPLOYMENT BY TECHNOLOGY

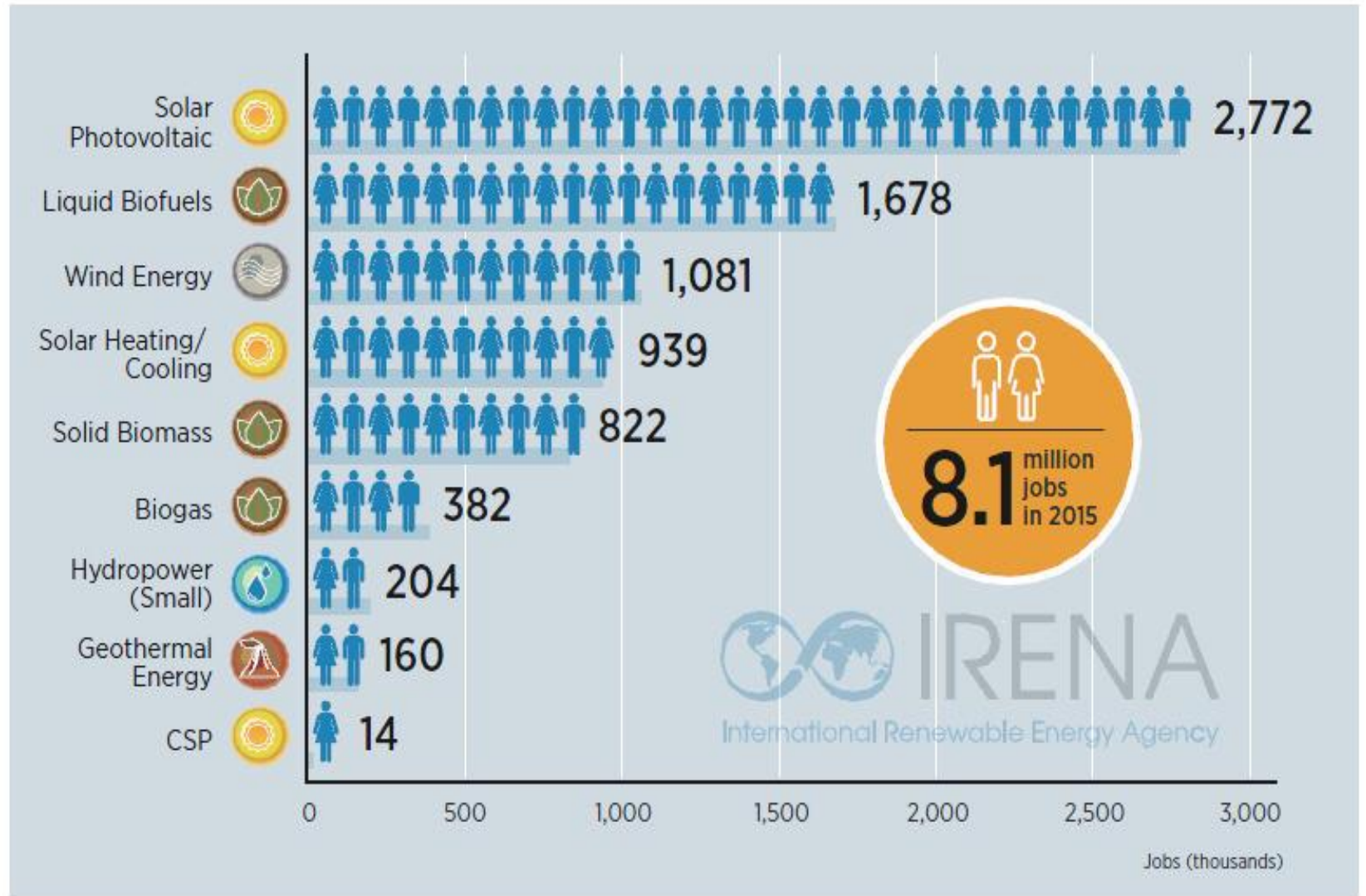

EEE Graduates

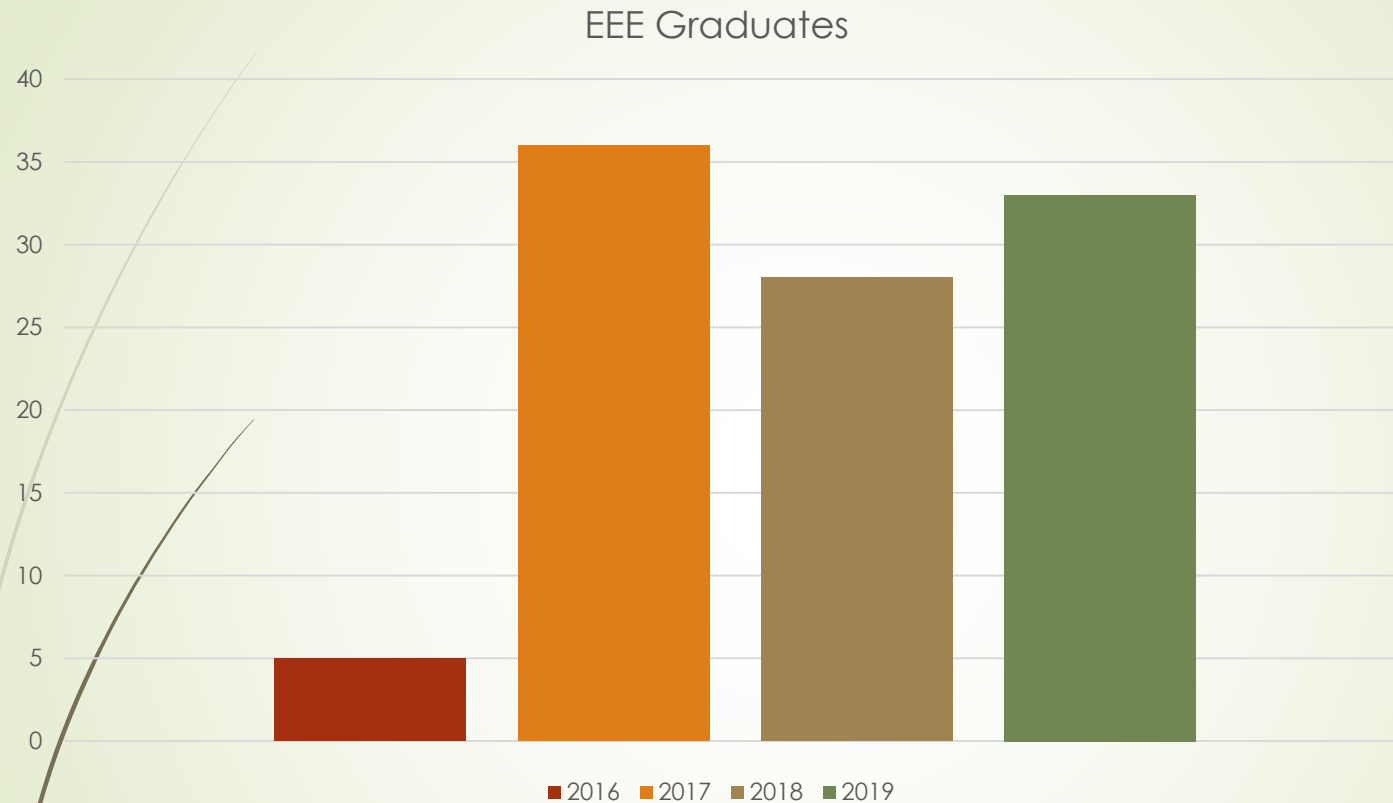

- Program started in Fall 2013.
- 102 Graduates till Summer 2019.
- 216 registered students in all levels in 2019/2020

EEE Graduates

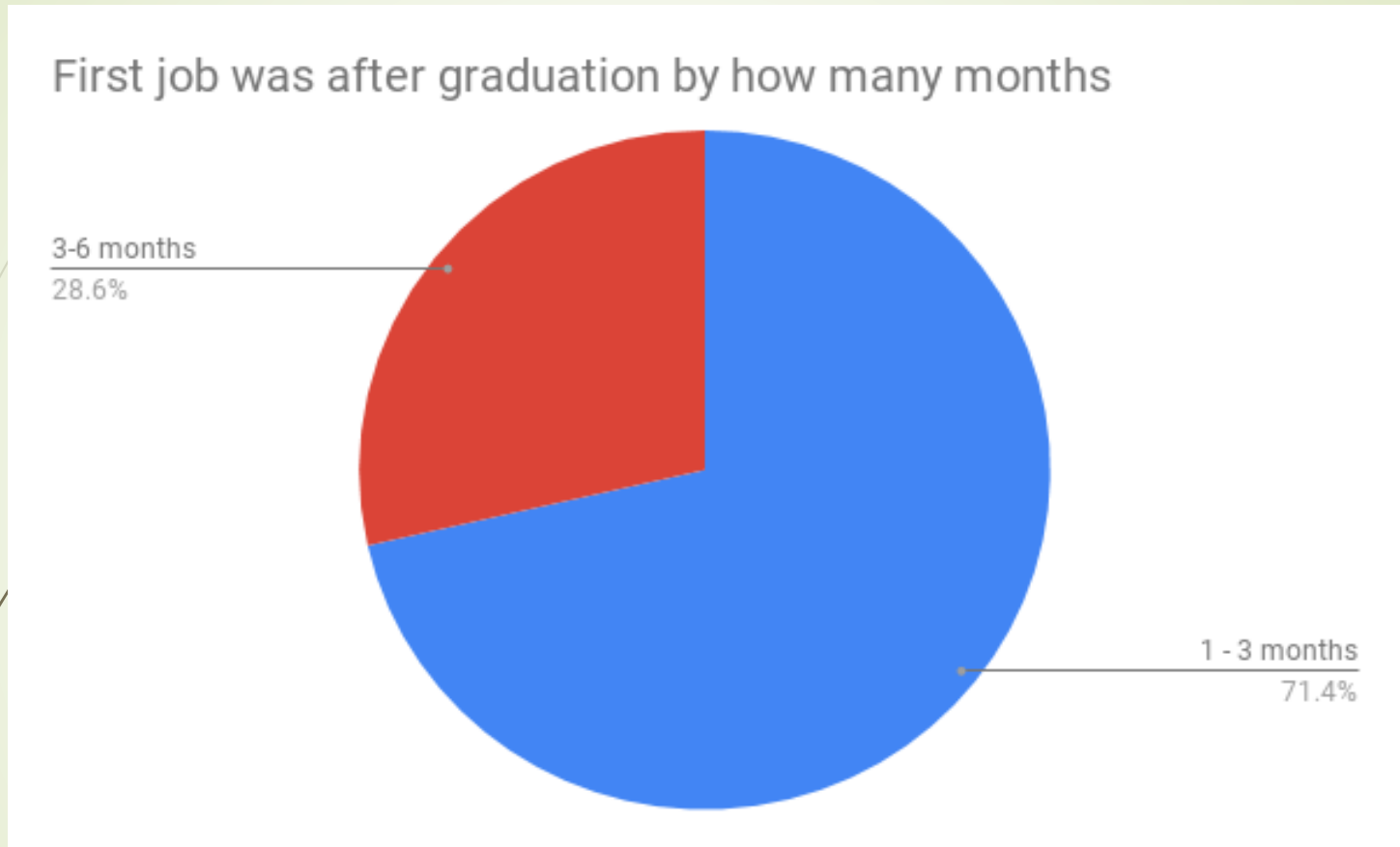

- 100% of our graduates were employed within 6 months of graduation.
- 81% of their first jobs were EEE related

EEE Graduates

EEE graduates positions – December 2019



SOME APPLICATIONS RELATED TO **EEE** PROGRAM CURRICULUM

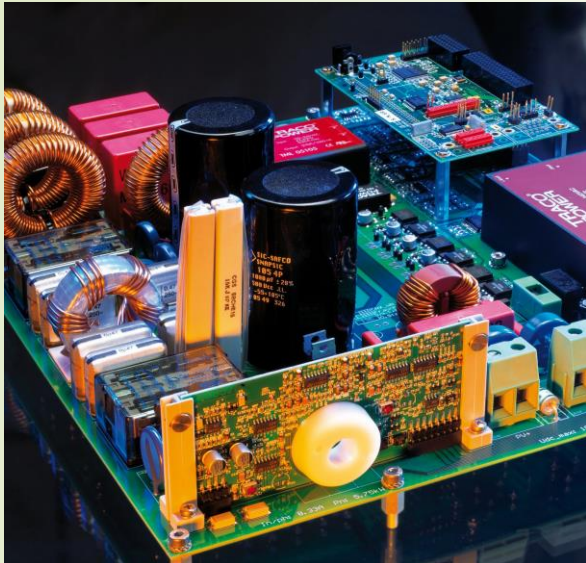

Power electronics



MAGLEV Monorails



Wind Power



PV Power

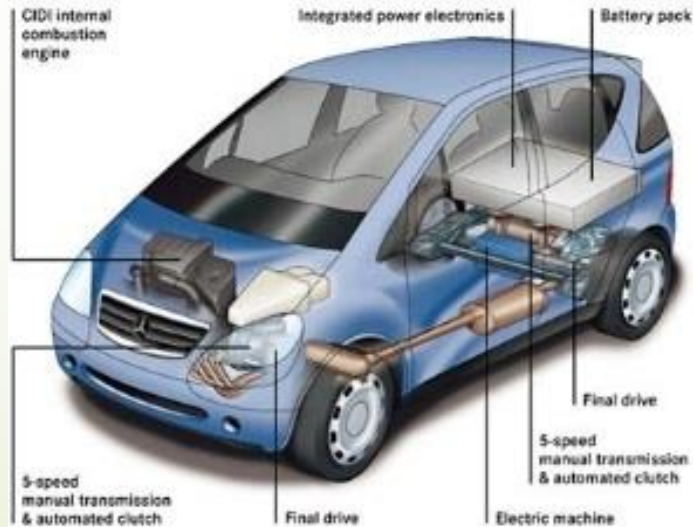

Electric Vehicles

SOME APPLICATIONS RELATED TO **EEE** PROGRAM CURRICULUM



Power systems



Industrial Automation



Energy Efficiency

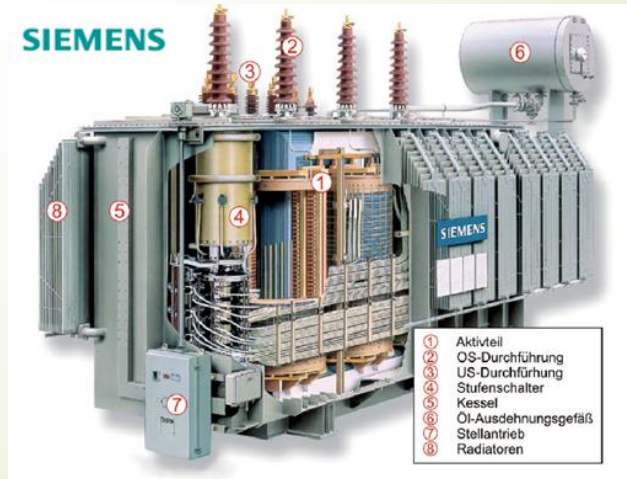

- ① Aktivteil
- ② OS-Durchführung
- ③ US-Durchführung
- ④ Stufenschalter
- ⑤ Kessel
- ⑥ Öl-Ausdehnungsgefäß
- ⑦ Stellantrieb
- ⑧ Radiatoren

Transformer Design

Renewable Energy and Micro-grid applications

Classical Power System

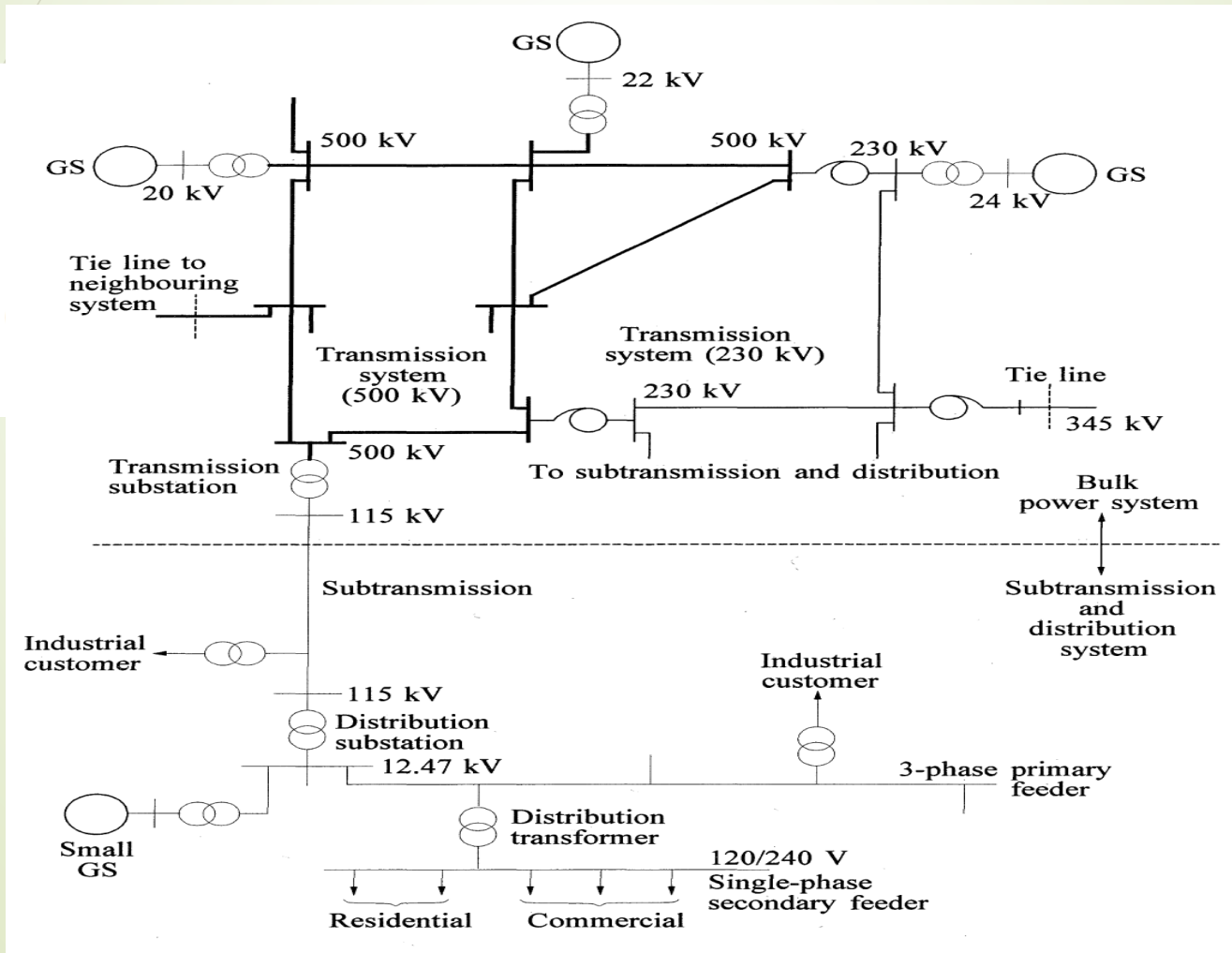

Renewable Energy and Micro-grid applications

SMART GRID

A vision for the future — a network of integrated microgrids that can monitor and heal itself.

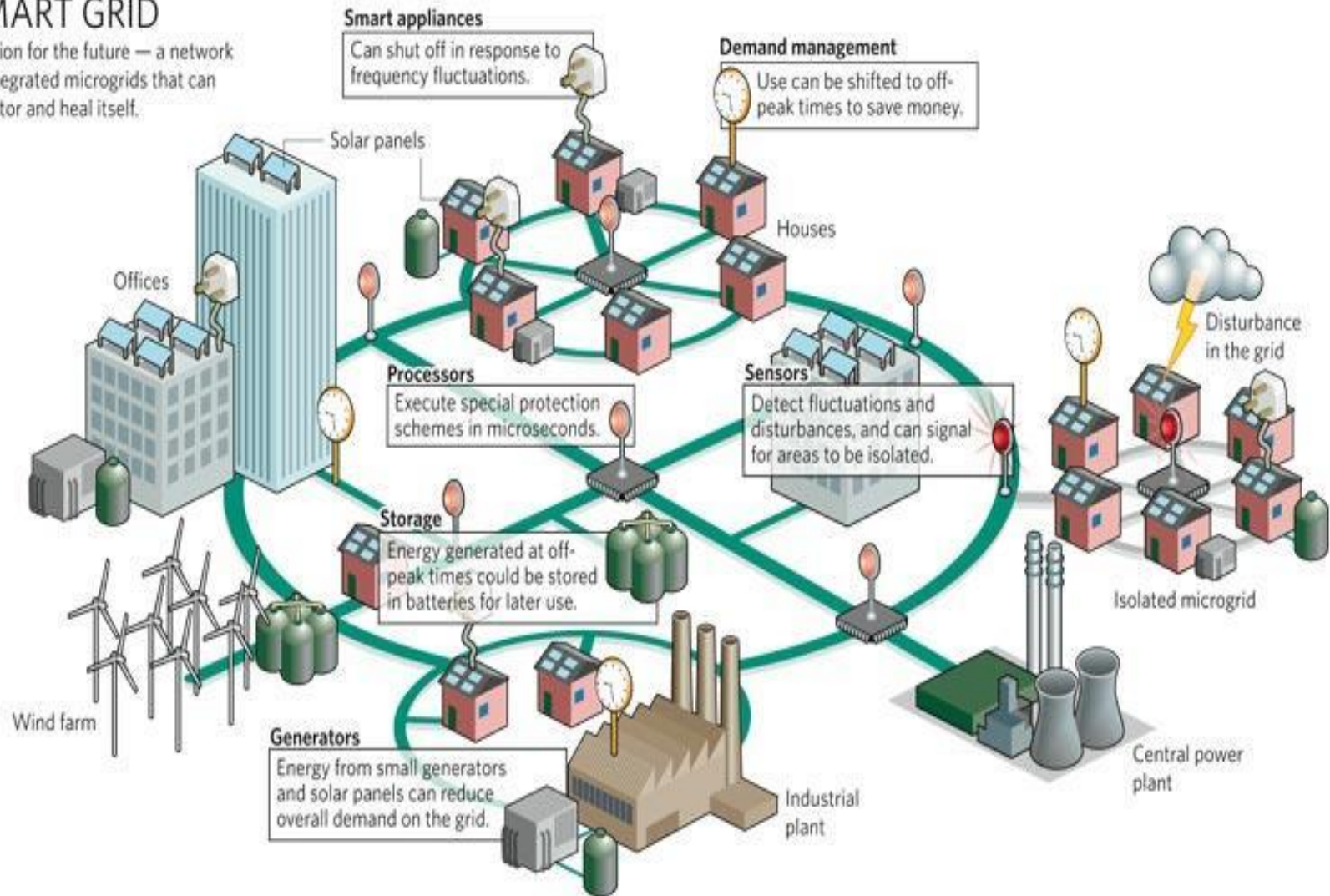



Samples of **EEE** Graduation
Projects
2016-2019



Design And Implementation Of A Cost Efficient E-bike



Cairo University

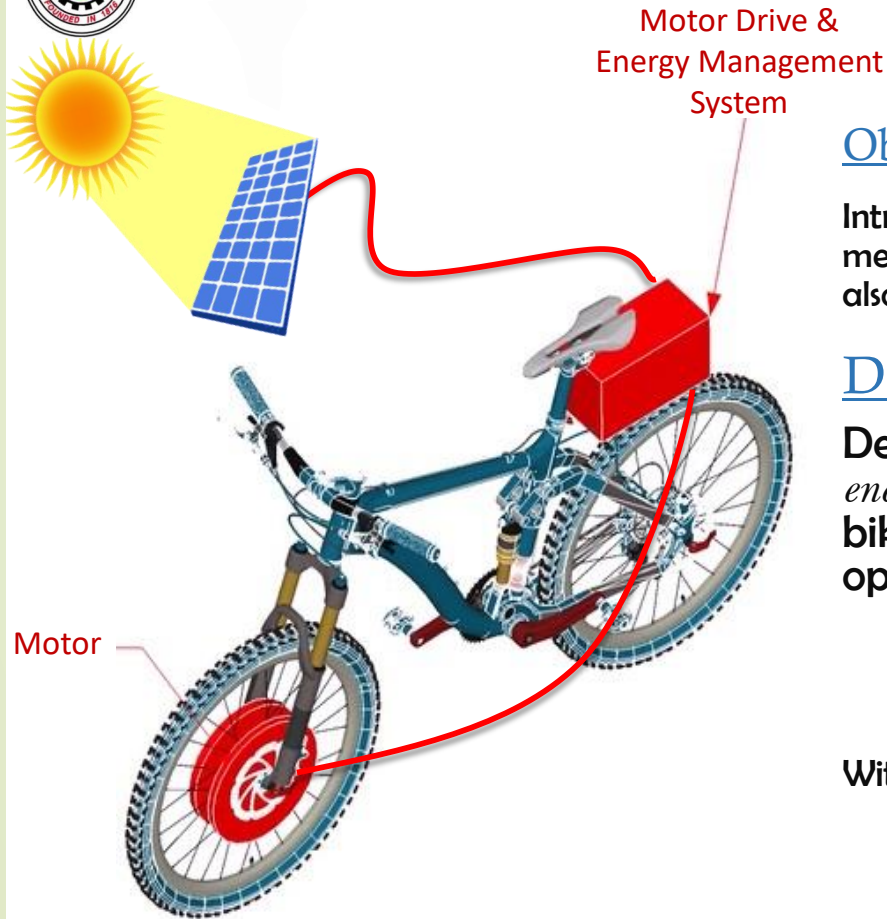

Objective:

Introducing to the Egyptian market a public transportation method with a low initial investment cost, locally implemented, also user & eco friendly.

Description:

Designing & implementing a *motor drive* and an *energy management system* to upgrade a regular bike to an e-bike; so it would have 3 modes of operations:

- *Pedals only*
- *Electric motor*
- *Pedal assist*

With 2 different charging sources:

- *Wall socket*
- *PV panel*

Wireless Power Transmitter

- Electric Vehicles (EV) industry is invading the automobile field competing the Internal Combustion (IC) industry since it introduces a zero-emission vehicles which are friendly to the environment.

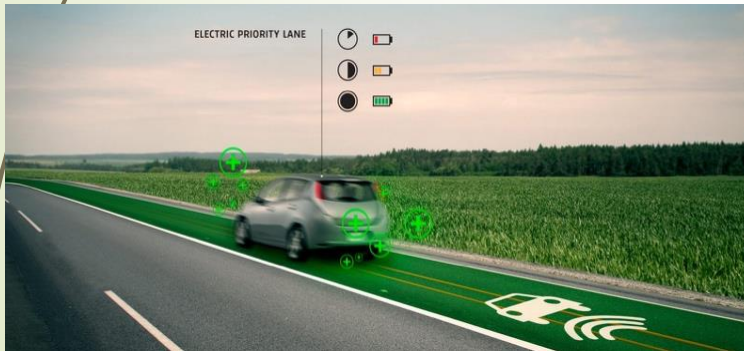

- Wireless power transfer (WPT), wireless power transmission or electromagnetic power transfer is the transmission of electrical energy without wires. The concept of WPT can resolve several issues regarding EV but the most significant one is that you can drive and charge your car simultaneously.

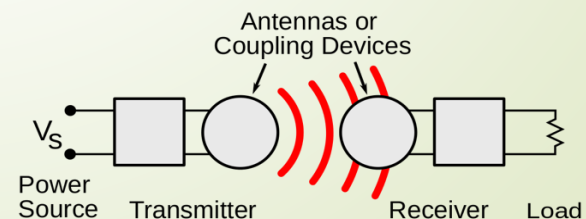



Hybrid Micro-grid operation and control for telecommunication



Cairo University

Project Sponsored by **Vodafone**

- **Project description:** Study and implement **hybrid power supply configurations** for **telecommunication sites** to maximize the penetration of **renewable energy** while satisfying the operational constraints like:
 - **DC and AC Voltage stability**
 - **Frequency stability**
 - **Power quality**
 - **System autonomy**
 - **Energy storage lifetime**
- **Project objective:** Design the system including
 - **Hybrid energy storage system and its control**
 - **Power converters control**
 - **Power management system**
 - **Energy management system**
 - **Graphical user interface**
 - **Economic analysis**





Smart Green Hospital



Cairo University

Distribution

- | | |
|------------------------------------|-------------------------------------|
| 1) Load estimation. | 10) Bus bar routing and sizing. |
| 2) Lighting. | 11) Cable routing. |
| 3) Sockets. | 12) Cable trays sizing and routing. |
| 4) Circuit breakers. | 13) UPS sizing. |
| 5) Cables sizing. | 14) Power factor correction. |
| 6) Distribution boards. | 15) Earthing. |
| 7) Lifts and fire pumps. | 16) Voltage drop calculations. |
| 8) HVAC . | 17) Short circuit calculations. |
| 9) Feeding system and room sizing. | 18) Ecodial and protection. |
| | 19) Light current. |

KNX

- KNX devices are building automation devices sponsored by Schneider electric.
- 3D room model (Macket) will be done to demonstrate the various devices functionalities and automation scenarios.

3D view:

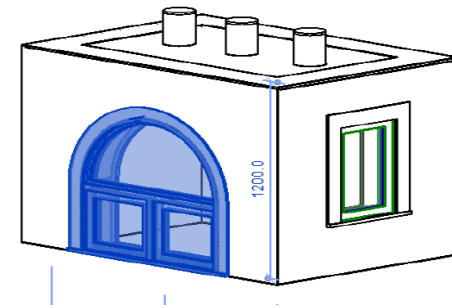

Energy Analysis and Management

• Summary:

Automation systems and industrial plants are growing increasingly complex, with more flexible production in larger plants. So more insights into plant performance is needed with less and less people to do the job. Data storage and transactions needs to be reliable, cyber secure, and with high capacity.

• Objective:

The aim of our project is to fully design and implement energy data acquisition system to monitor different types of energies such as electricity, heat and compressed air pressure from different sites to a centralized server. Followed by reports and technical analysis to the findings to make plan for continuous improvements in the following areas, Energy Saving, Co2 Emission monitoring and Improving energy efficiency.

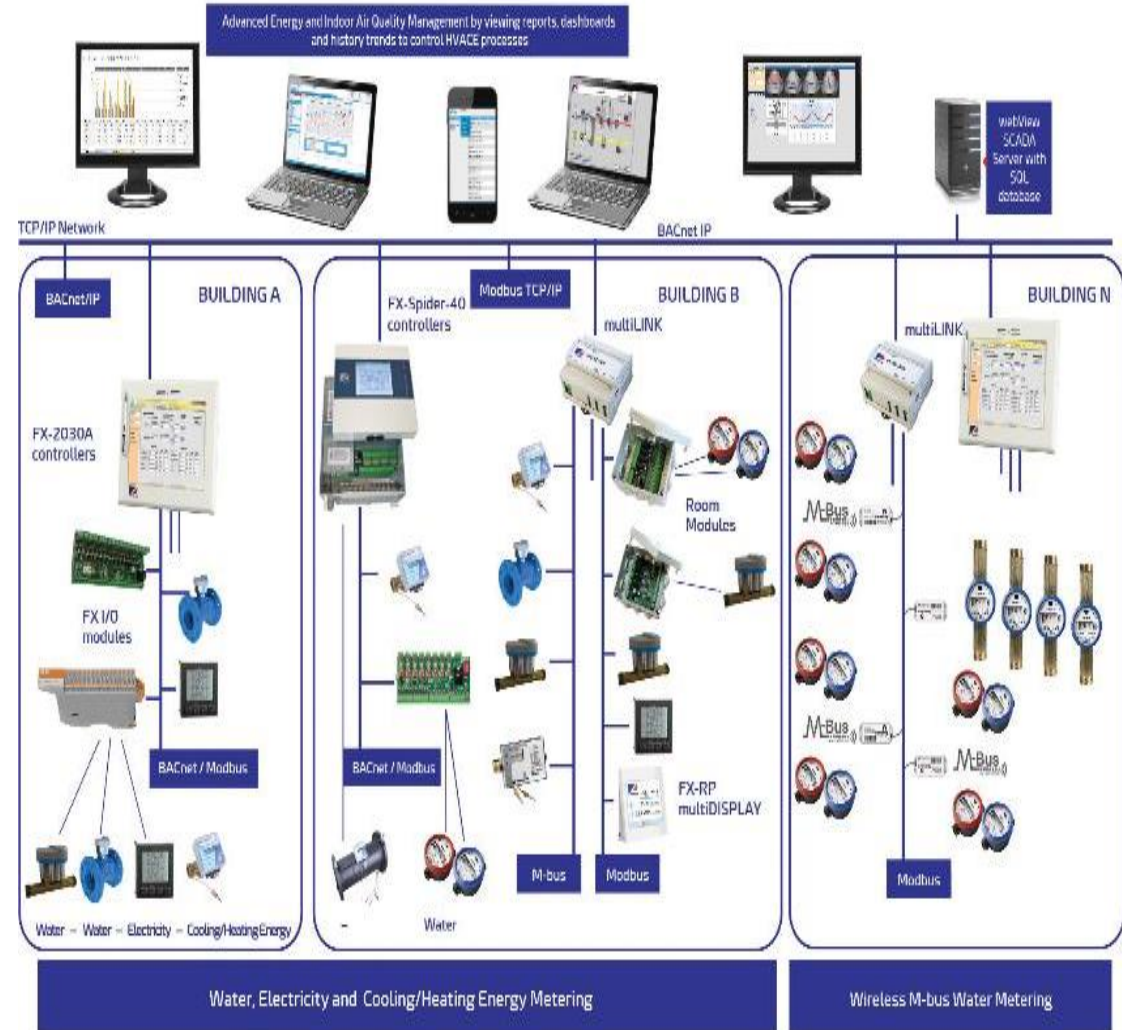



Smart Grid



Cairo University

- **Project description:**

- The aim of this project is to construct an isolated system, formed by distributed energy resources (DER), energy storage system (ESS), and loads that are electrically interconnected and hierarchically controlled.

- **Objectives:**

- Connect PV inverter to the system as a distributed energy resource (DER).
- Programming PLC to implement Demand Side Management.
- Use of Smart Meter to measure: energy - power - current - voltage and transmit to PLC
- Develop the needed communication system to exchange the information between the different controllers

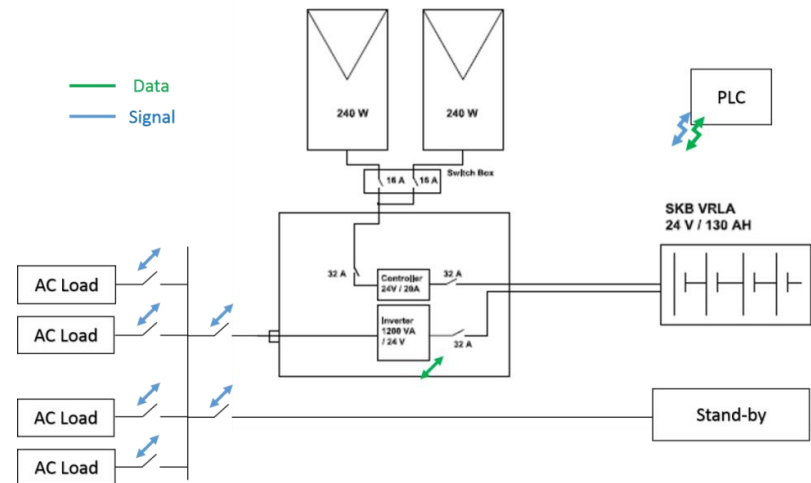

Electrical Installation For Hotel

The project includes design for the electrical requirements to the building as the lighting system, sockets, HVAC system, light current system, cable sizing, short circuit calculations ,Single Line Diagram, and Earthing system simulation kit

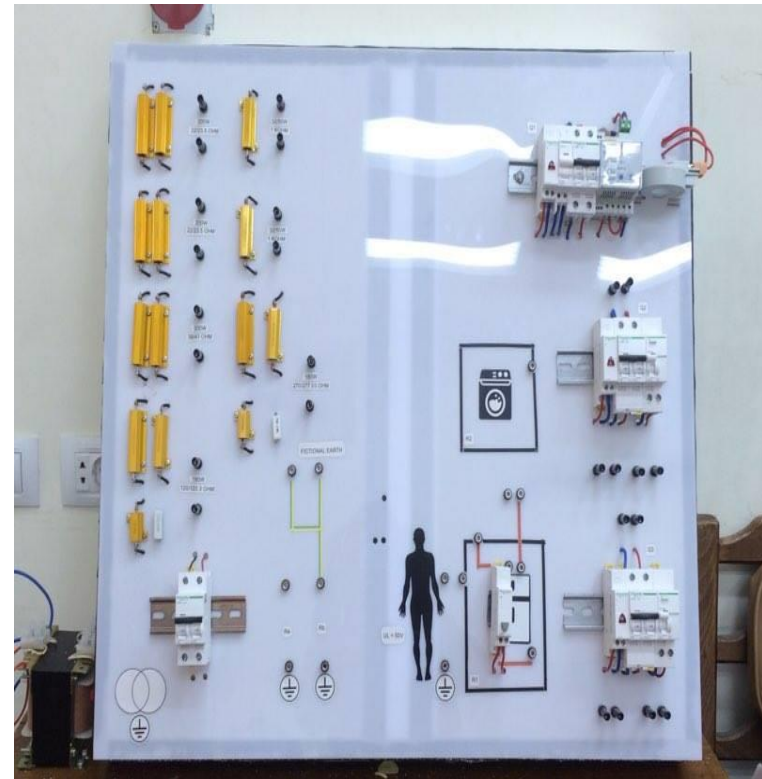

Delta Robot

- design and implement a delta robot for picking and placing light objects.



Design, Monitoring and control of solar parabolic trough using PLC & SCADA

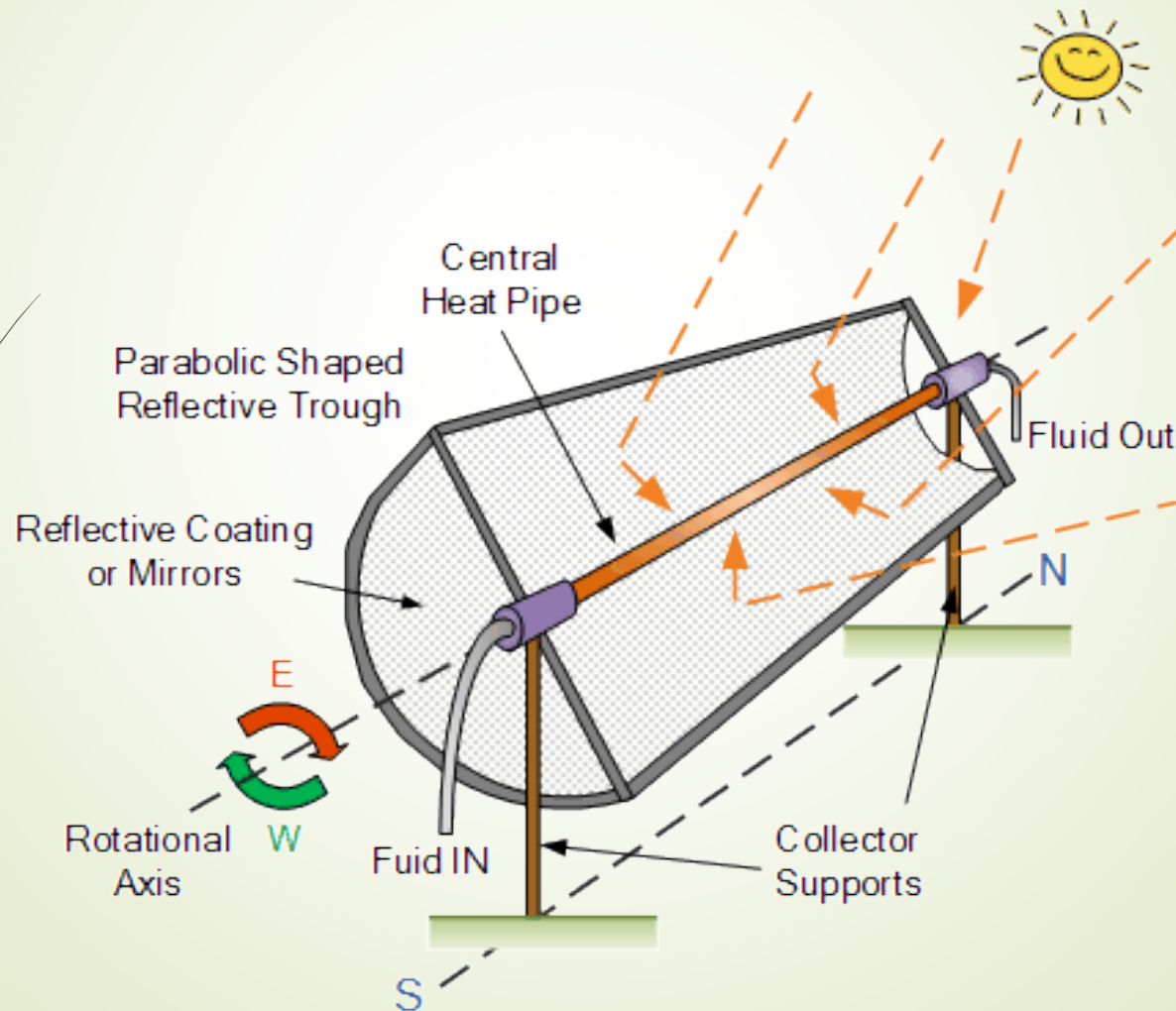

Design of a PLC-Based control system for grain storage silos



Contact Info

EEE Program Coordinators

Prof. Dr. Mohamed Sakr

Email: sakr@sakronline.com

Associate Prof. Dr. Mohamed Shawky Saad

Email: mssaad@eng.cu.edu.eg

EEE GP and IT coordinator

Dr. Tamer Mamdouh Abdo

Email: tamermabdo@cu.edu.eg