



**Cairo University**  
**Faculty of Engineering**  
**Credit Hours System**



# **Electrical Energy Engineering Program EEE**

**June 2019**

# Electrical Engineers: What they do ?



Electrical engineers specify, design and supervise the construction or manufacture of systems and equipment that produce, distribute and/or use electricity. They also maintain, operate and manage these systems and equipment.

# Electrical Engineers: What they do ?



- Develop, design or update specifications and designs for electrical systems and equipment
- Design methods to generate, distribute and manage electricity
- Design automated and computerised methods to control industrial processes
- Calculate the cost of projects, and materials needed
- Supervise the installation and maintenance of systems and equipment

# Electrical Energy Engineering: A Growing Field for Opportunities



- Global transition into renewable and sustainable forms of energy.
- Worldwide trend for electrical applications for more energy saving and green economy.
- Constant growth of the local market for renewable energy and industrial automation.

FIGURE 1: RENEWABLE ENERGY EMPLOYMENT BY TECHNOLOGY

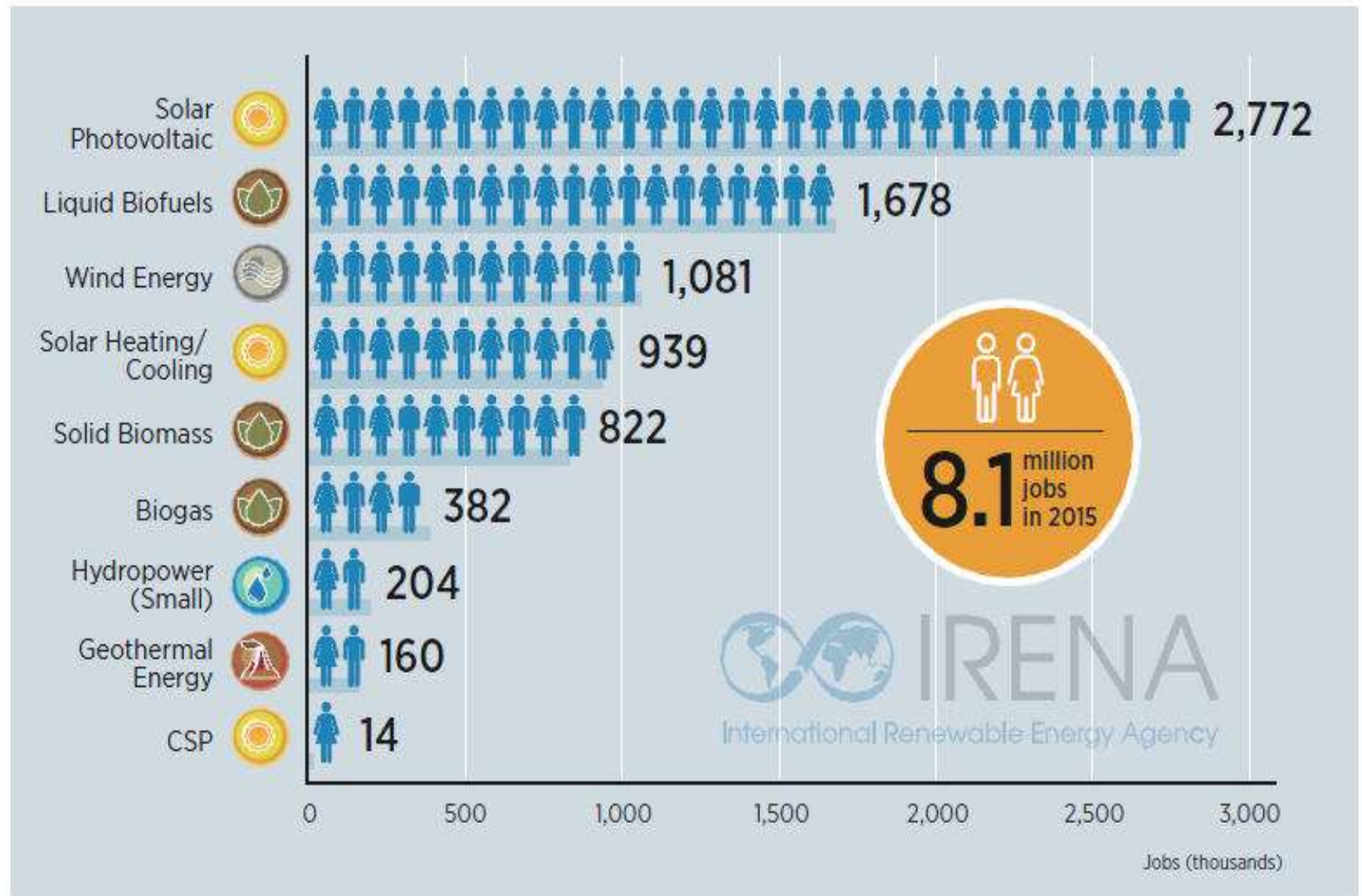

# EEE Graduates

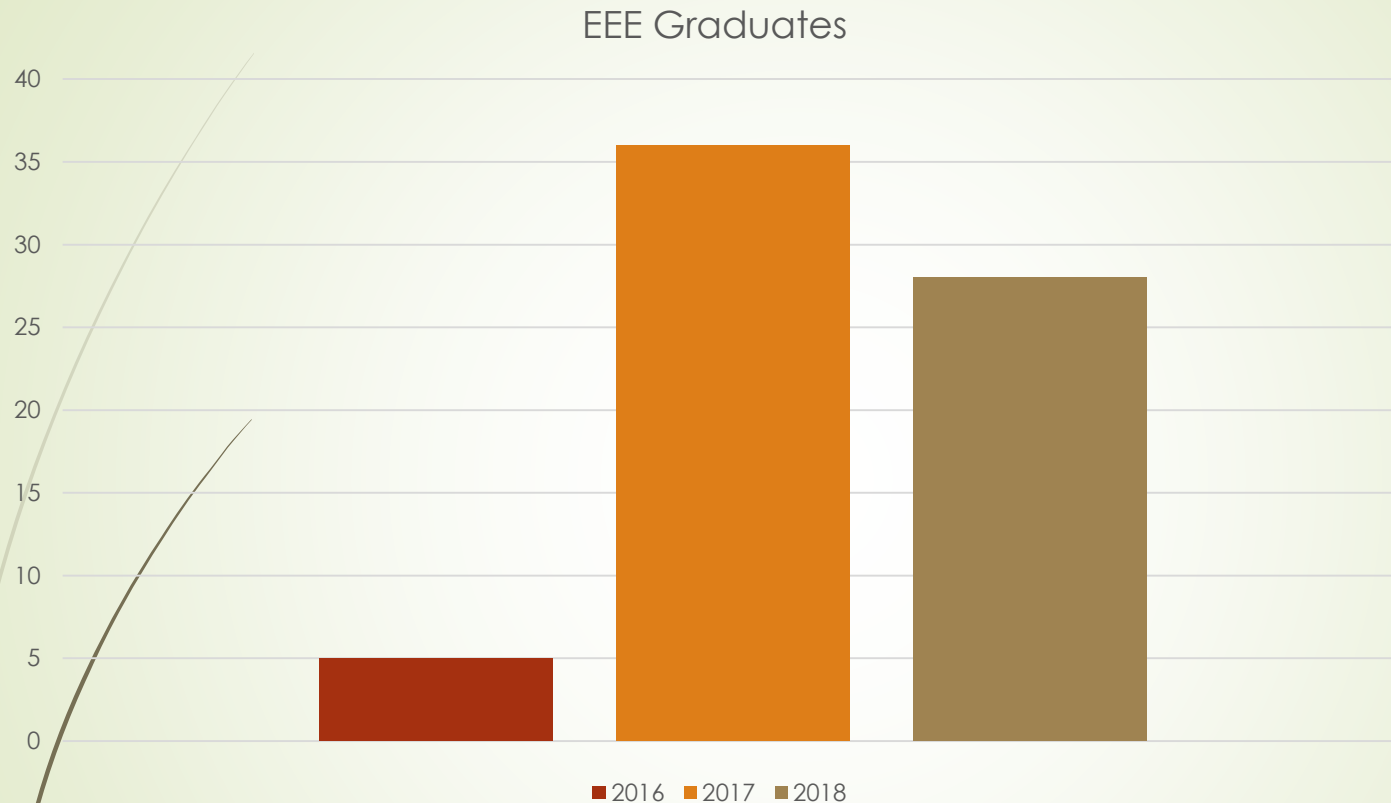

- Program started in Fall 2013.
- 69 Graduates till Summer 2018.
- 215 registered students in all levels in 2018/2019

# EEE Graduates

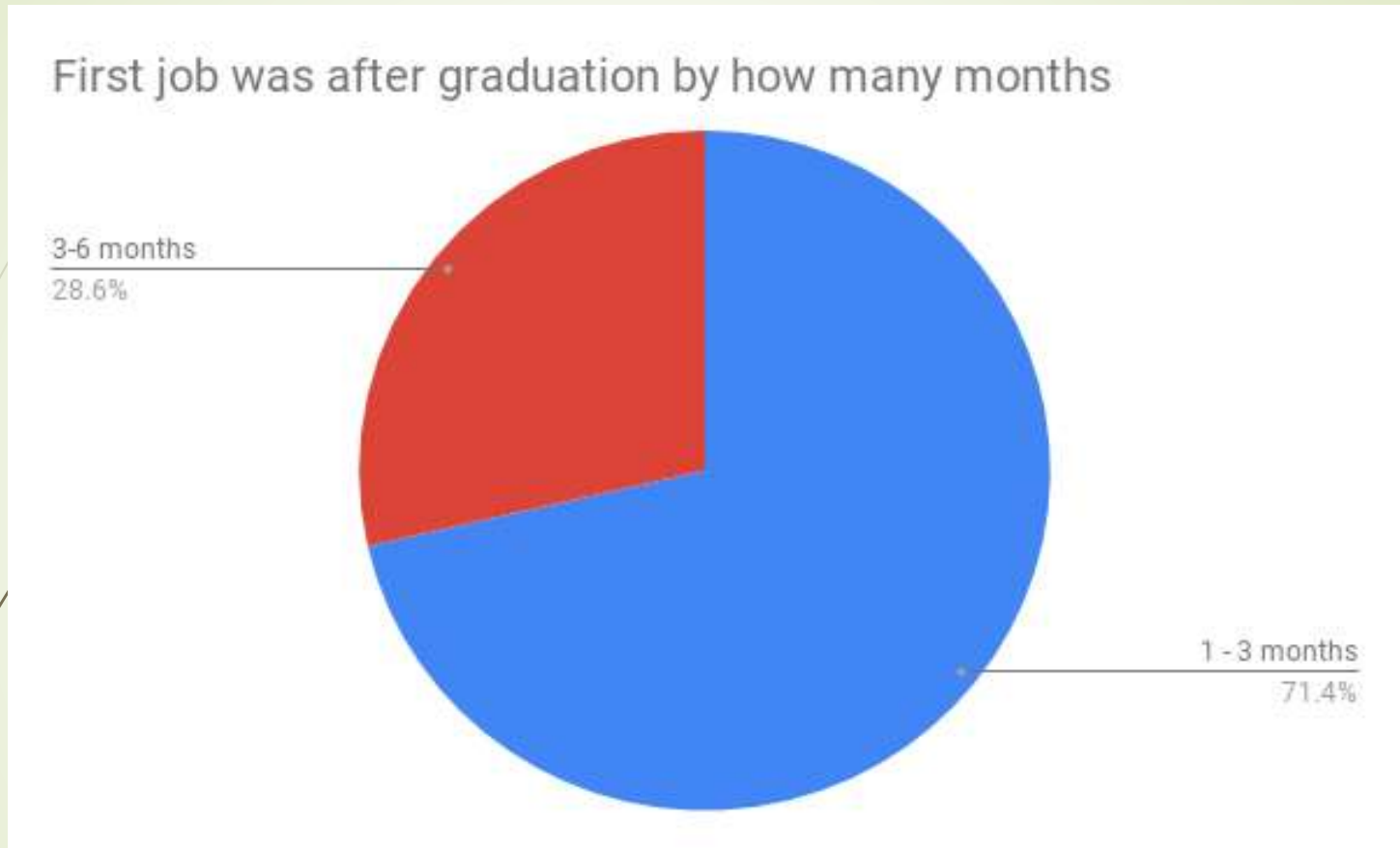

- 100% of our graduates were employed within 6 months of graduation.
- 81% of their first jobs were EEE related

# EEE Graduates

EEE graduates positions – December 2018

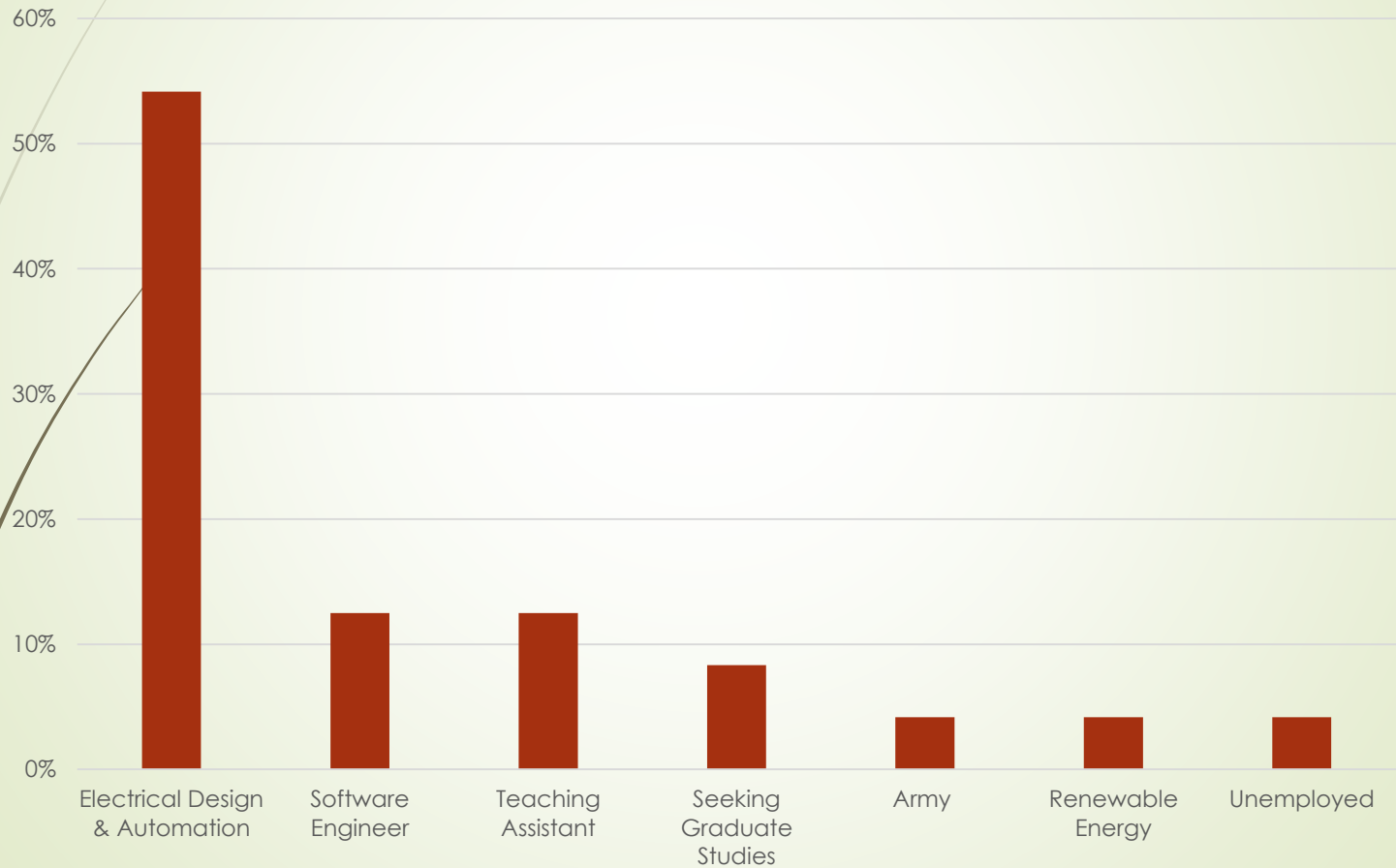



# SOME APPLICATIONS RELATED TO **EEE** PROGRAM CURRICULUM



**Power electronics**



**MAGLEV Monorails**



**Wind Power**



**PV Power**



**Electric Vehicles**

# SOME APPLICATIONS RELATED TO **EEE** PROGRAM CURRICULUM



**Power systems**



**Industrial Automation**



**Energy Efficiency**

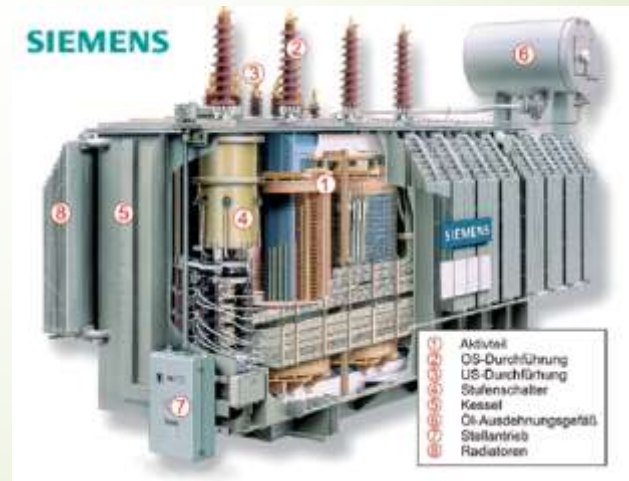

**Transformer Design**

# Renewable Energy and Micro-grid applications

## Classical Power System

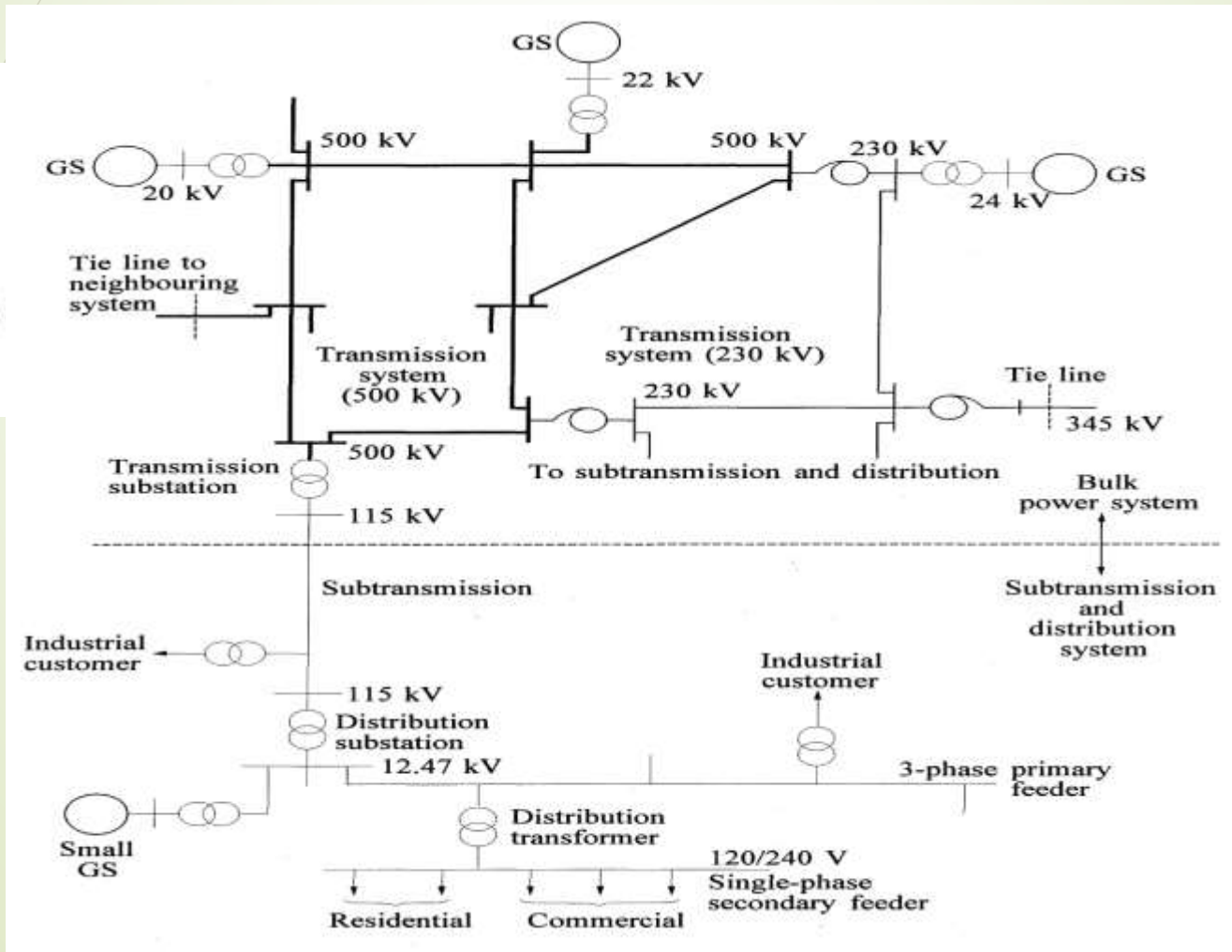

# Renewable Energy and Micro-grid applications

## SMART GRID

A vision for the future — a network of integrated microgrids that can monitor and heal itself.

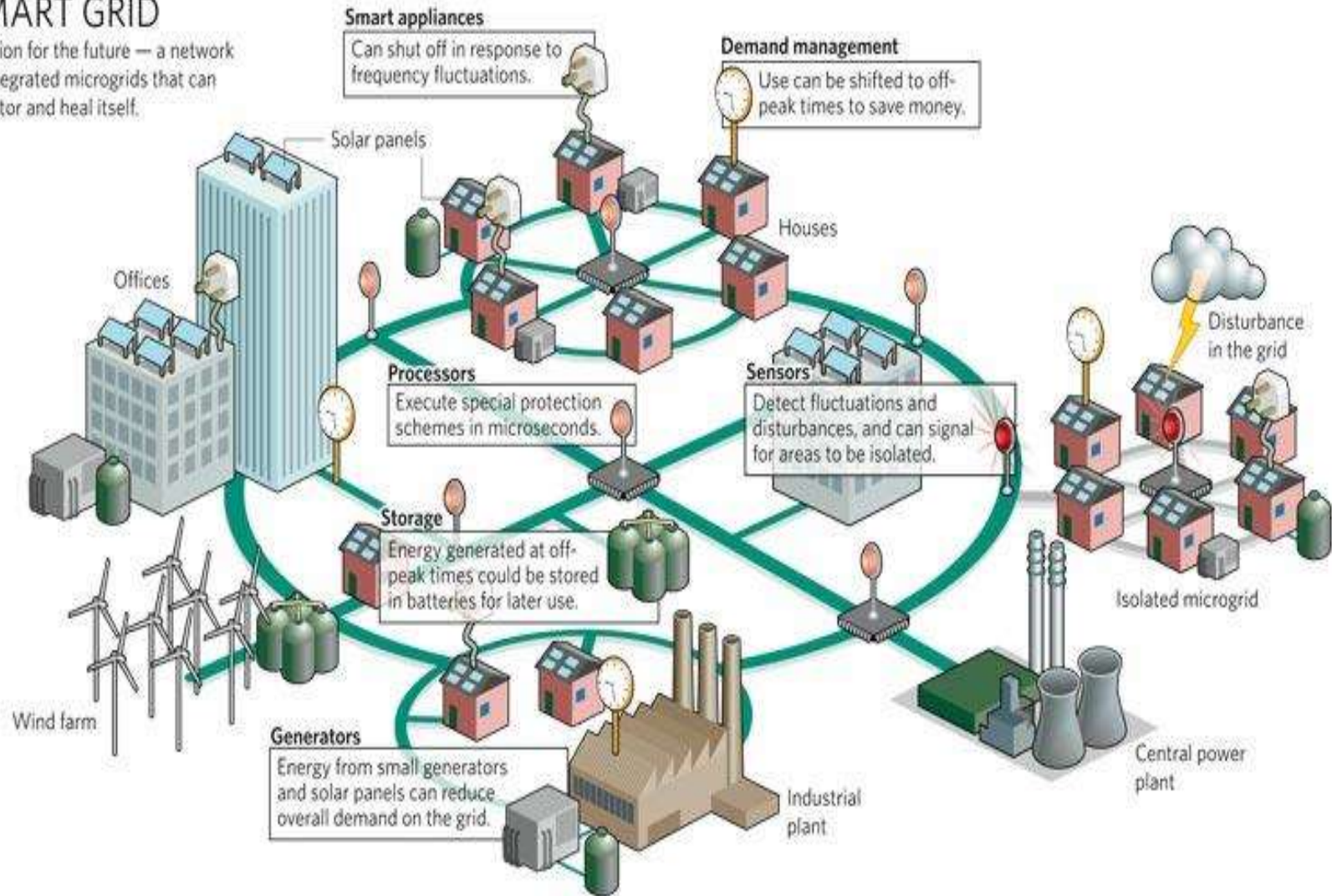



Samples of **EEE** Graduation  
Projects  
*2016-2019*



# Design And Implementation Of A Cost Efficient E-bike

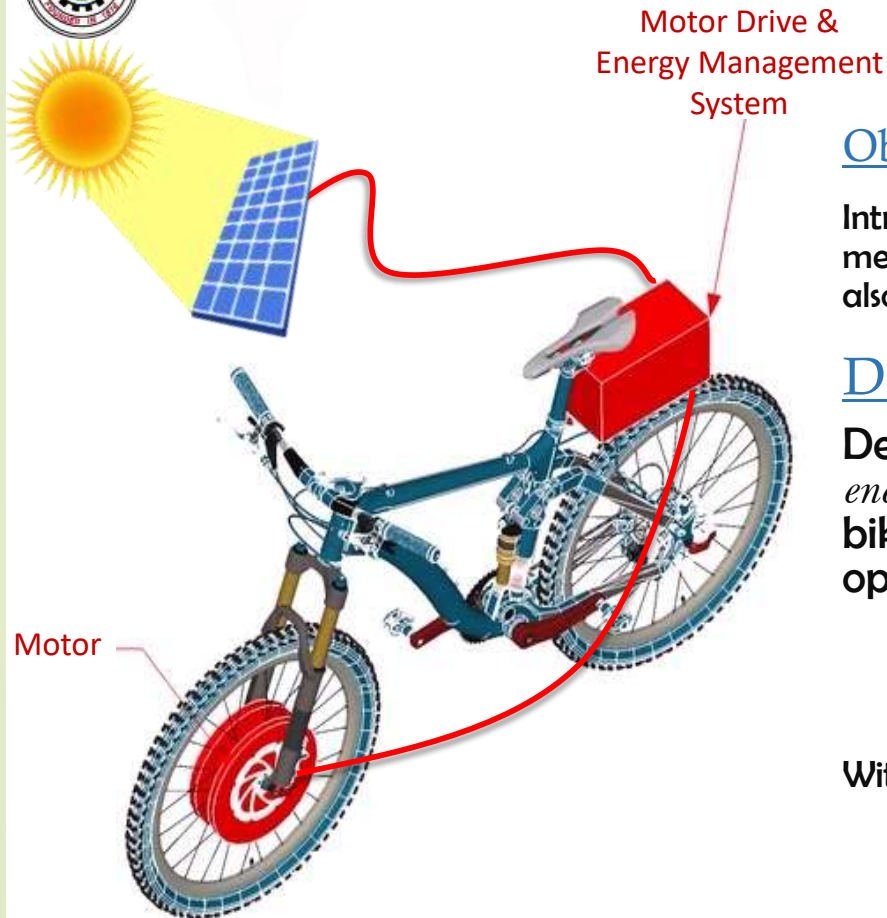

## Objective:

Introducing to the Egyptian market a public transportation method with a low initial investment cost, locally implemented, also user & eco friendly.

## Description:

Designing & implementing a *motor drive* and an *energy management system* to upgrade a regular bike to an e-bike; so it would have 3 modes of operations:

- *Pedals only*
- *Electric motor*
- *Pedal assist*

With 2 different charging sources:

- *Wall socket*
- *PV panel*

# Wireless Power Transmitter

- Electric Vehicles (EV) industry is invading the automobile field competing the Internal Combustion (IC) industry since it introduces a zero-emission vehicles which are friendly to the environment.



- Wireless power transfer (WPT), wireless power transmission or electromagnetic power transfer is the transmission of electrical energy without wires. The concept of WPT can resolve several issues regarding EV but the most significant one is that you can drive and charge your car simultaneously.

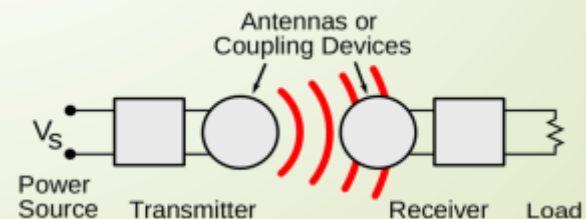



# Hybrid Micro-grid operation and control for telecommunication



Project Sponsored by **Vodafone**

- **Project description:** Study and implement **hybrid power supply configurations** for **telecommunication sites** to maximize the penetration of **renewable energy** while satisfying the operational constraints like:
  - **DC and AC Voltage stability**
  - **Frequency stability**
  - **Power quality**
  - **System autonomy**
  - **Energy storage lifetime**
- **Project objective:** Design the system including
  - **Hybrid energy storage system and its control**
  - **Power converters control**
  - **Power management system**
  - **Energy management system**
  - **Graphical user interface**
  - **Economic analysis**







# Smart Green Hospital



Cairo University

## Distribution

- |                                    |                                     |
|------------------------------------|-------------------------------------|
| 1) Load estimation.                | 10) Bus bar routing and sizing.     |
| 2) Lighting.                       | 11) Cable routing.                  |
| 3) Sockets.                        | 12) Cable trays sizing and routing. |
| 4) Circuit breakers.               | 13) UPS sizing.                     |
| 5) Cables sizing.                  | 14) Power factor correction.        |
| 6) Distribution boards.            | 15) Earthing.                       |
| 7) Lifts and fire pumps.           | 16) Voltage drop calculations.      |
| 8) HVAC .                          | 17) Short circuit calculations.     |
| 9) Feeding system and room sizing. | 18) Ecodial and protection.         |
|                                    | 19) Light current.                  |

## KNX

- KNX devices are building automation devices sponsored by Schneider electric.
- 3D room model (Macket) will be done to demonstrate the various devices functionalities and automation scenarios.

3D view:

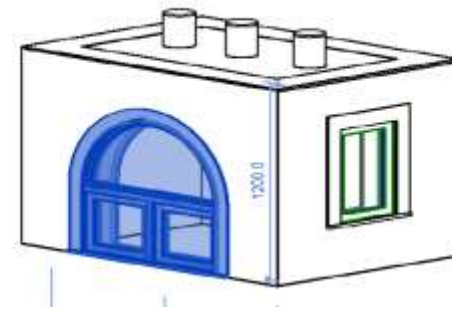



# Energy Analysis and Management

## • Summary:

Automation systems and industrial plants are growing increasingly complex, with more flexible production in larger plants. So more insights into plant performance is needed with less and less people to do the job. Data storage and transactions needs to be reliable, cyber secure, and with high capacity.

## • Objective:

The aim of our project is to fully design and implement energy data acquisition system to monitor different types of energies such as electricity, heat and compressed air pressure from different sites to a centralized server. Followed by reports and technical analysis to the findings to make plan for continuous improvements in the following areas, Energy Saving, Co2 Emission monitoring and Improving energy efficiency.

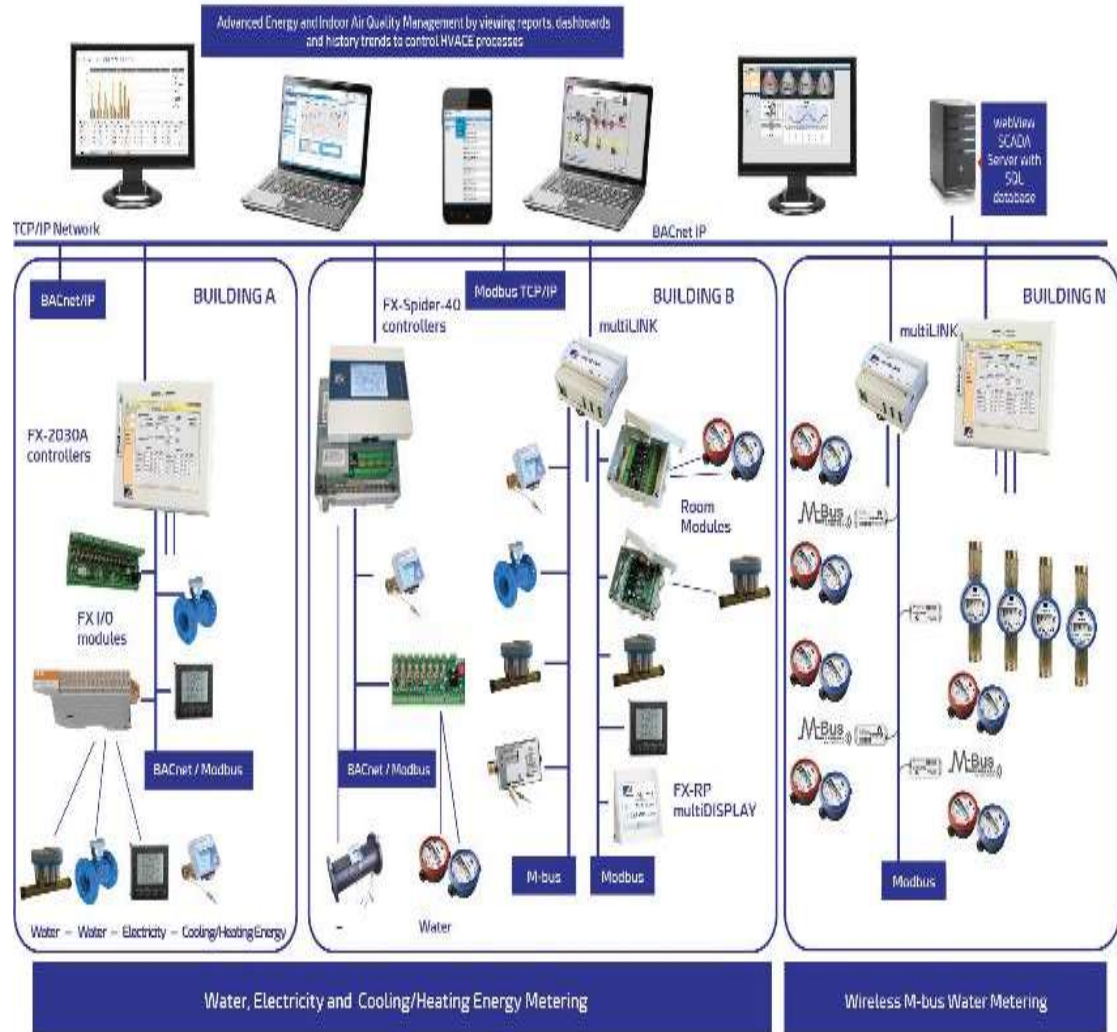



# Smart Grid



Cairo University

- **Project description:**

- The aim of this project is to construct an isolated system, formed by distributed energy resources (DER), energy storage system (ESS), and loads that are electrically interconnected and hierarchically controlled.

- **Objectives:**

- Connect PV inverter to the system as a distributed energy resource (DER).
- Programming PLC to implement Demand Side Management.
- Use of Smart Meter to measure: energy - power - current - voltage and transmit to PLC
- Develop the needed communication system to exchange the information between the different controllers

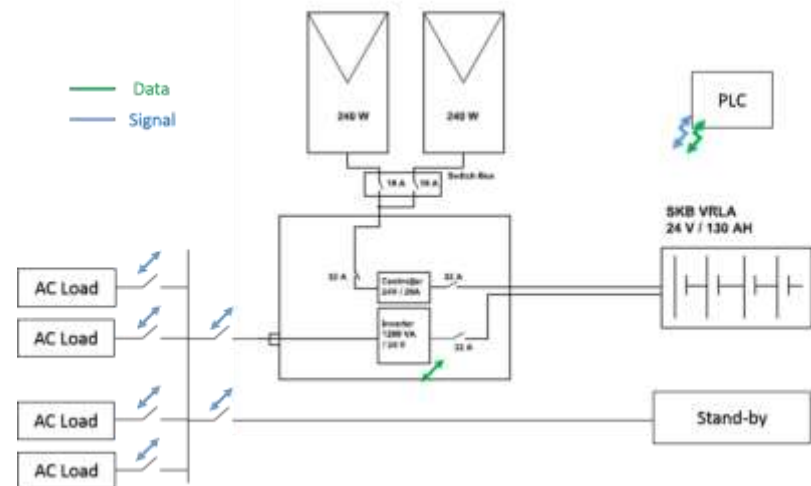

# Electrical Installation For Hotel

The project includes design for the electrical requirements to the building as the lighting system, sockets, HVAC system, light current system, cable sizing, short circuit calculations ,Single Line Diagram, and Earthing system simulation kit

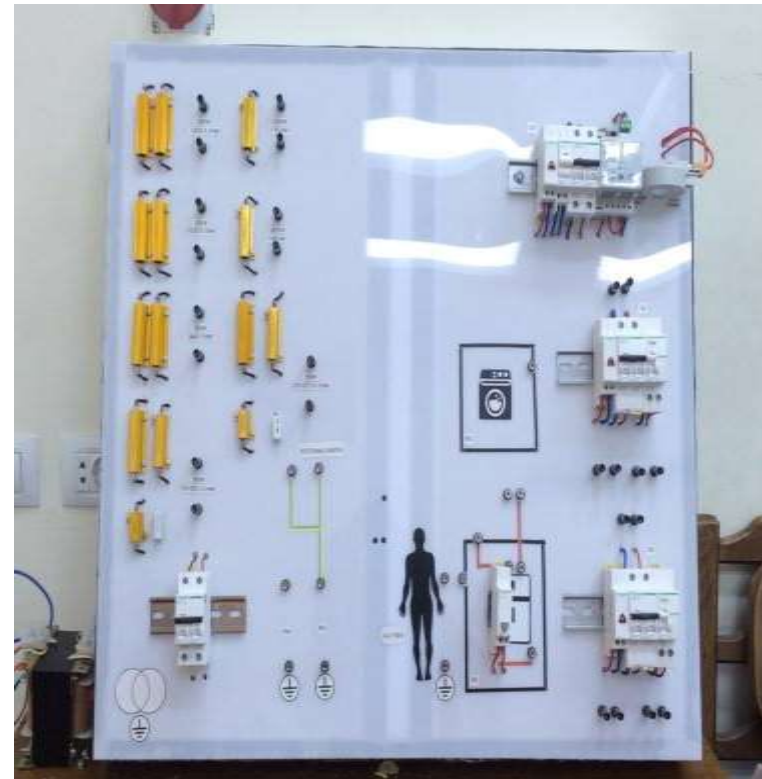

# Delta Robot

- design and implement a delta robot for picking and placing light objects.



# Design, Monitoring and control of solar parabolic trough using PLC & SCADA

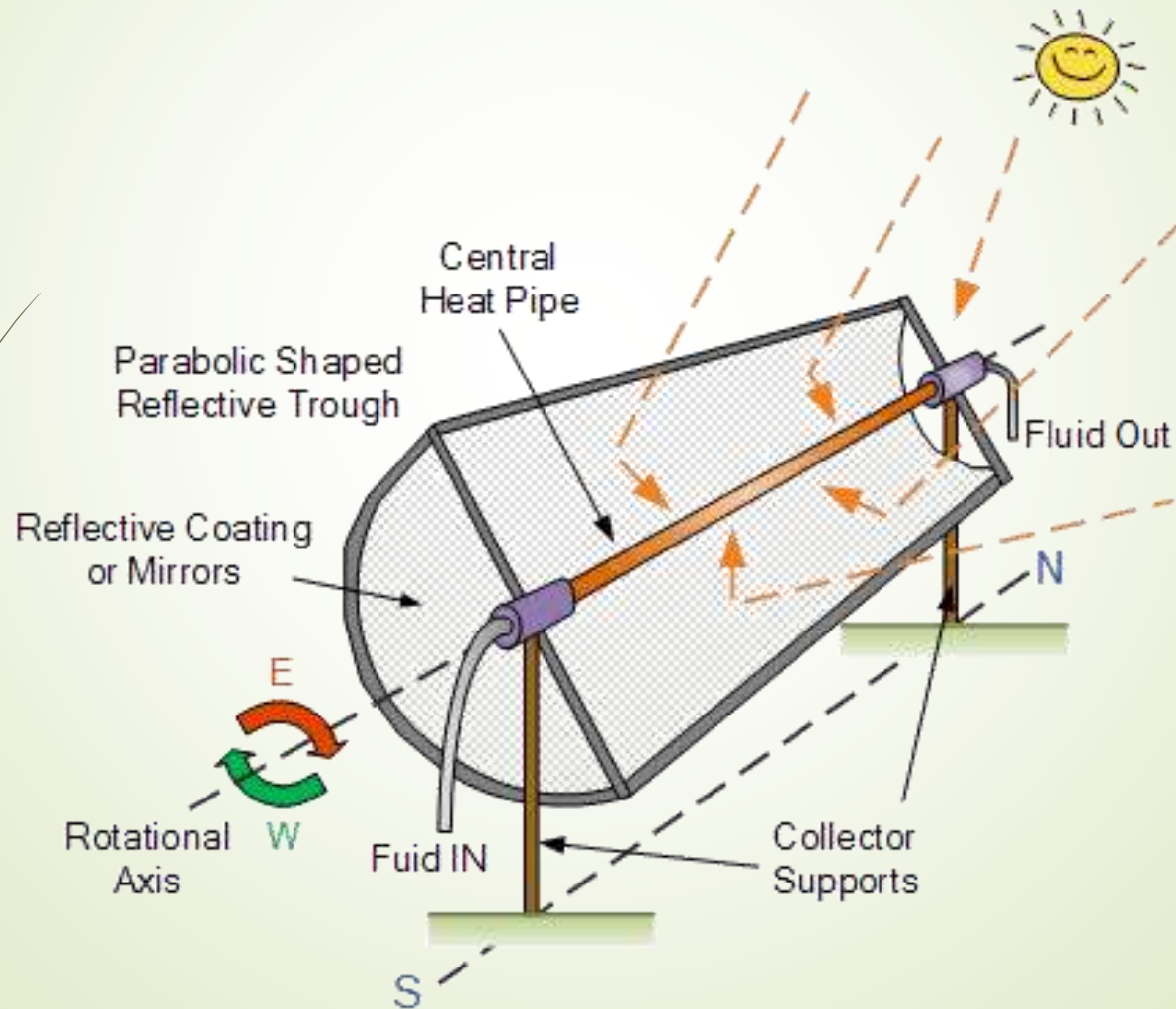

# Design of a PLC-Based control system for grain storage silos



# Contact Info

## EEE Program Coordinators

Prof. Dr. Mohamed Sakr

Email: [sakr@sakronline.com](mailto:sakr@sakronline.com)

Associate Prof. Dr. Mohamed Shawky Saad

Email: [mssaad@eng.cu.edu.eg](mailto:mssaad@eng.cu.edu.eg)

## EEE IT and GP coordinator

Dr. Tamer Mamdouh Abdo

Email: [tamermabdo@cu.edu.eg](mailto:tamermabdo@cu.edu.eg)